



# TC 200

Generation 2

## CONSTANT TENSION-TYPE PACKAGE HOLDER

Package holder for unwinding creels matched to weaving, pultrusion and pre-preg applications dedicated to technical fibers.

The TC200 is designed to guarantee constant yarn tension throughout the spool unwinding process.

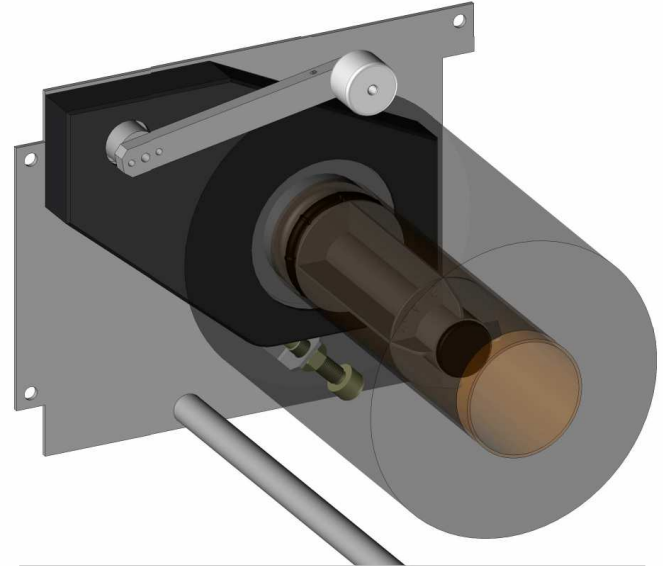

### Properties :

Tension applied	From 50 to 600 grammes
Accuracy	±10%
Spool diameter	From 74mm to 200mm
Unwinding speed	< 50 m/min

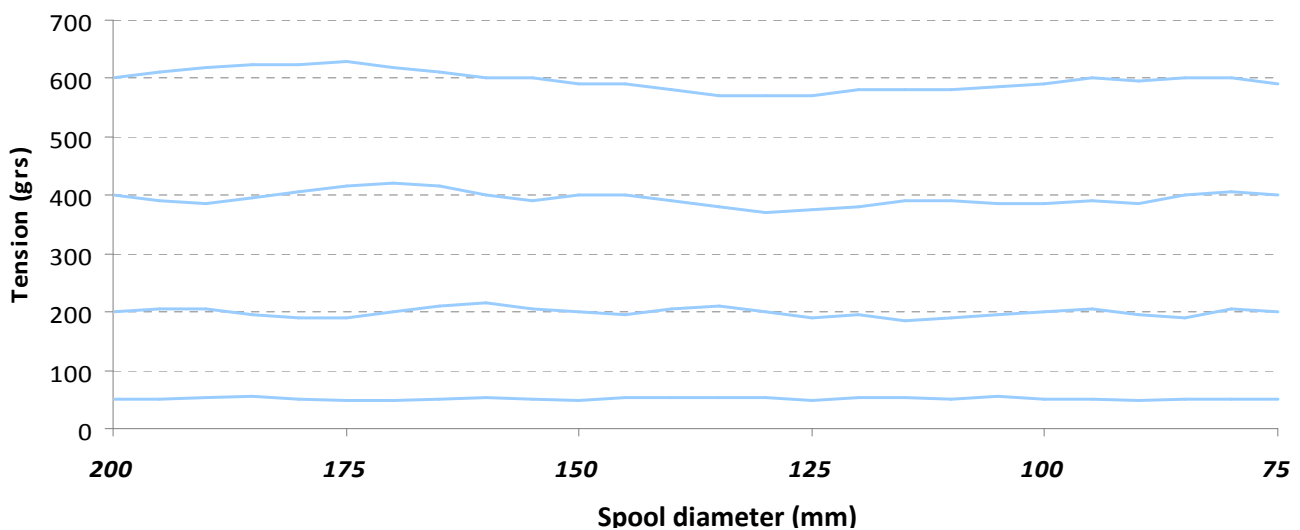

## Constructions Mécaniques du Grimaud

E-mail : [cmg@cmg-France.com](mailto:cmg@cmg-France.com)

Site : [www.cmg-france.com](http://www.cmg-france.com)

141, route des Alpes

38630 VEYRINS-THUELIN – France

Tél : +33 (0) 474 889 390 - Fax : +33 (0) 474 889 764